

ANEMOGENNHTPIES KATHETOY AEONA
ALLCOM WIND GENERATORS VERTICAL

ΠΟΛΥ ΧΑΜΗΛΗΣ ΟΧΛΗΣΗΣ

PRICE LIST

Date : 19/1/2008

	Description	TEM	EURO	TOTAL	
ALLCC	200w generator	1	450,00	450,00	
ALLCC	3blades 1m long 220mm width connection part	1	270,00	270,00	
	controller/charger board	1	95,00	95,00	
0,2KW ΣΥΝΟΛΟ" TOTAL:				815+ΦΠΑ	
ALLCC	500w Generator	1	650,00	650,00	
ALLCC	blades 3x1,5m long 220mm W +connection part	1	450,00	450,00	
ALLCC	controller charger	1	300,00	300,00	
ALLCC	inverter	1	650,00	650,00	
0,5KW ΣΥΝΟΛΟ" TOTAL:				2050+ΦΠΑ	
ALLCC	1Kw Generator	1	950,00	950,00	
ALLCC	blades 220mm width + connection parts	1	900,00	900,00	
ALLCC	controller charger	1	360,00	360,00	
ALLCC	inverter	1	1150,00	1150,00	
1 KW ΣΥΝΟΛΟ" TOTAL:				3360+ ΦΠΑ	

ALLCC	2KW GENERATOR	1	2100,00	2100,00	
ALLCC	2KW CONTROLLER CHARGER	1	680,00	680,00	
ALLCC	INVERTER	1	1800,00	1800,00	
ALLCC	BLADE 220mm WIDTH X M LENGTH	1	2100,00	2100,00	
2kw ΣΥΝΟΛΟ TOTAL:				6680+ΦΠΑ	
ALLCC	3KW WIND TURBINE SYSTEM	1	2500,00	2500,00	
ALLCC	3KW CONTROLLER CHARGER	1	880,00	880,00	
ALLCC	INVERTER	1	2200,00	2200,00	
	BLADE 300mm WIDTH X M LENGTH	1	4000,00	4000,00	
	BLADE 220mm WIDTH X M LENGTH	1	3200,00	3200,00	
ALLCC	3KW ΣΥΝΟΛΟ TOTAL:			8780+φπα	
ALLCC	5kw Generator	1	3100,00	3100,00	
ALLCC	Controller Charger	1	900,00	900,00	
ALLCC	Inverter	1	3000,00	3000,00	
ALLCC	Blades X m 300 mm W ,+ connection parts	1	5600,00	5600,00	
ΣΥΝΟΛΟ TOTAL:				12600,00	

ΠΑΡΑΔΟΣΗ ΑΠΟ ΠΑΡΑΓΓΕΛΙΑ 45 ΗΜΕΡΕΣ

+ΦΠΑ...tel:00302104114832..... info@allcom.com.gr

ΠΟΛΥ ΧΑΜΗΛΗΣ ΟΧΛΗΣΗΣ

ΠΑΡΑΔΟΣΗ ΑΠΟ ΠΑΡΑΓΓΕΛΙΑ 45 ΗΜΕΡΕΣ +ΦΠΑ...tel:00302104114832..... info@allcom.com.gr



Brushless Generator 200W 24V
230rpm
Net Weight 7.5kg
Start Torque 0.05N.m

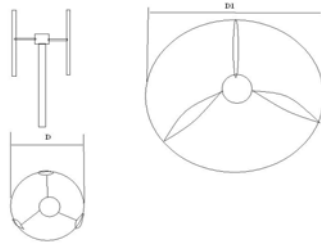
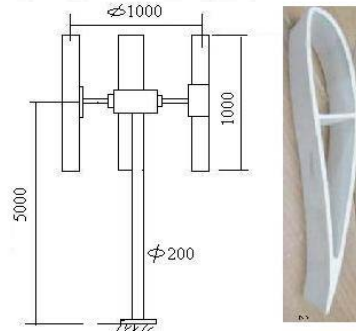
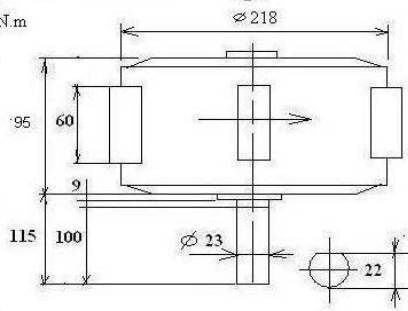
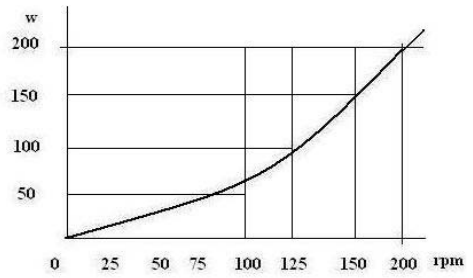
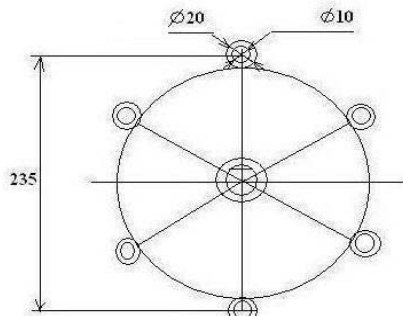

500K 36VDC GENERATOR

MAIN TECHNICAL DATA:
 RATED POWER OUTPUT, 500W
 RATED SPEED, 200RPM
 RATED VOLTAGE OUTPUT, 45VDC
 Rated Wind Speed 9m/s
 Cut in speed 2.5m/s Start Torque: 0.2 N.m

RATED CURRENT OUTPUT, 14A
 INSULATION CLASS B
 B4-Fe-B Outer Rotor

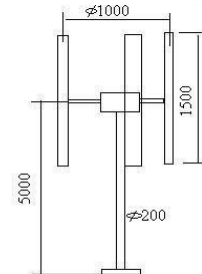
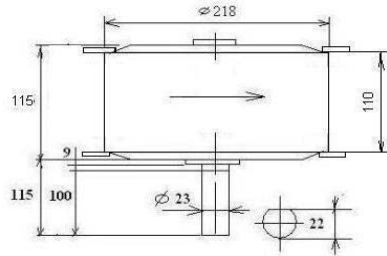
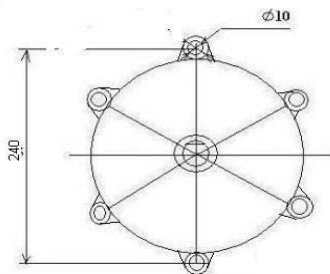
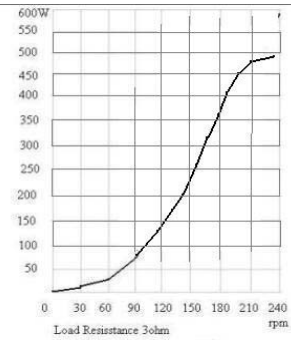
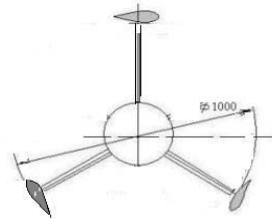

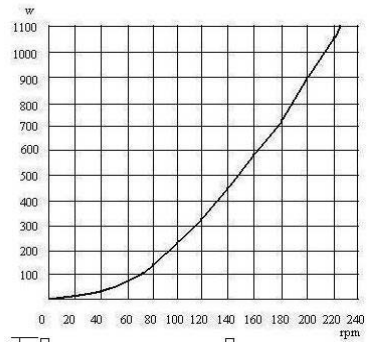

Magnetic Material
Nd-Fe-B
1000W
48VDC
210rpm
9m/s rated wind speed
2.5m/s cut in speed
Start Torque 0.5 N.m
15 kgs net weight

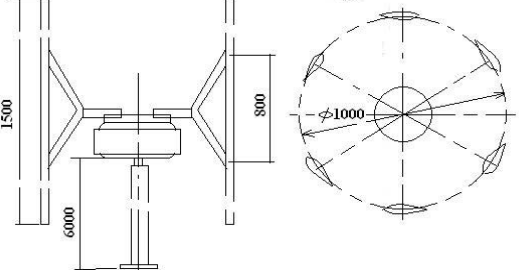
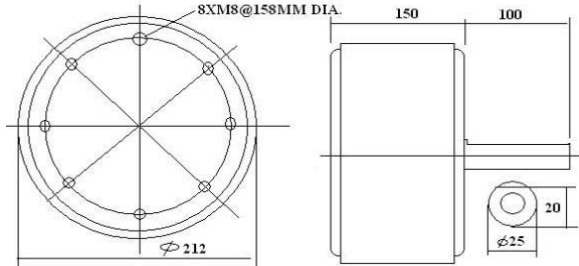

2KW48VDC Brushless Windmill Generator
 Vertical axle
 130rpm rated speed
 10m/s Rated Wind Speed
 3m/s Cut in Wind Speed
 Start Torque 7N.m
 Diameter 430mm
 Height 138mm
 Net Weight 55kgs

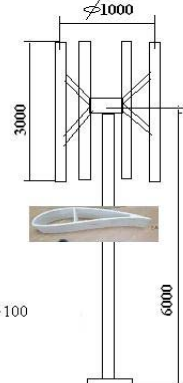
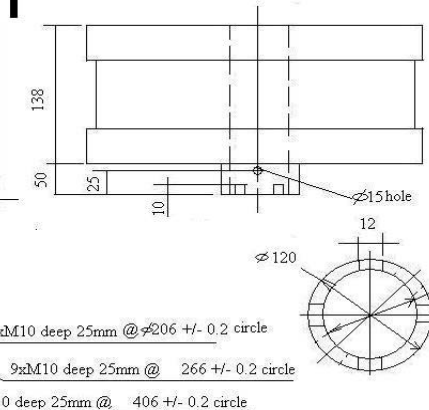
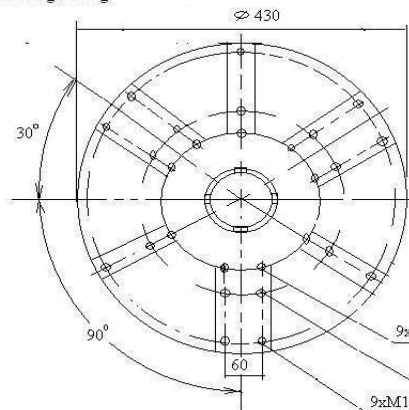
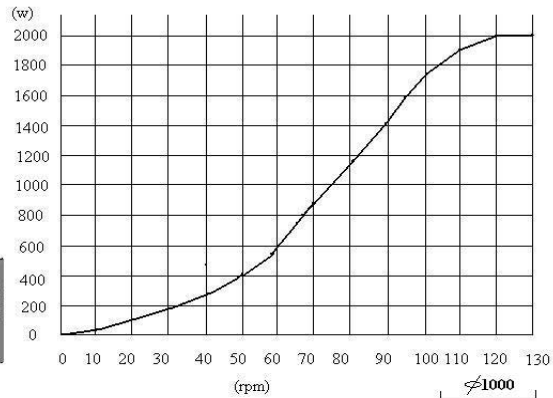
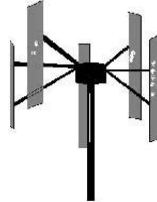

9xM10 deep 25mm @ ϕ 206 +/- 0.2 circle
 9xM10 deep 25mm @ 266 +/- 0.2 circle
 9xM10 deep 25mm @ 406 +/- 0.2 circle

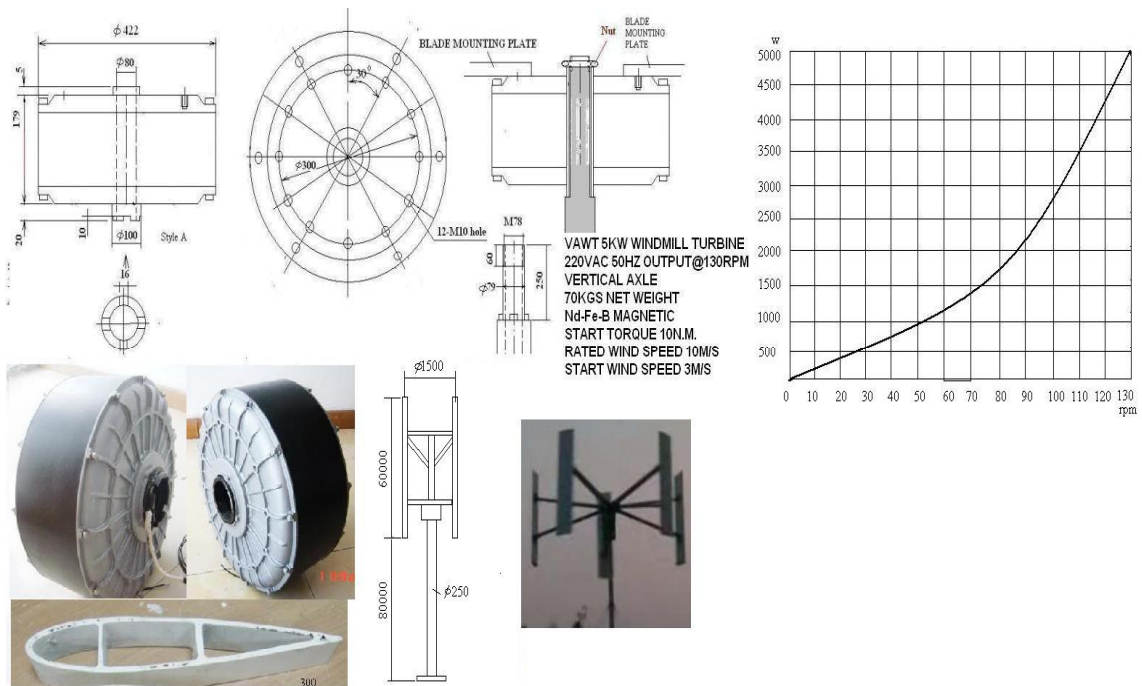
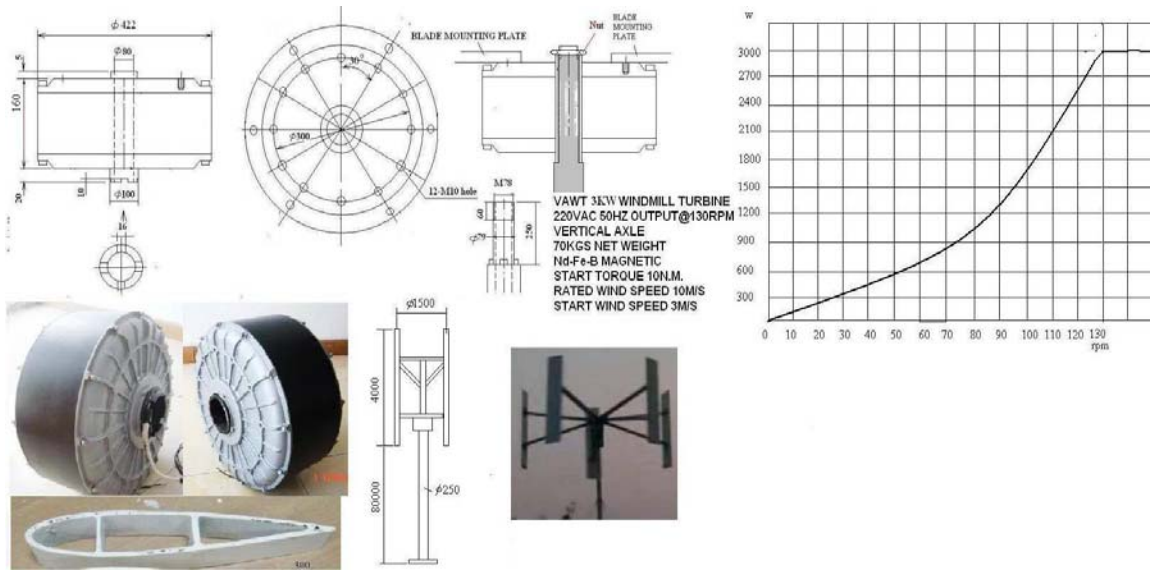

ALLCOM WIND GENERATORS VERTICAL WWW.ALLCOM.COM.GR